

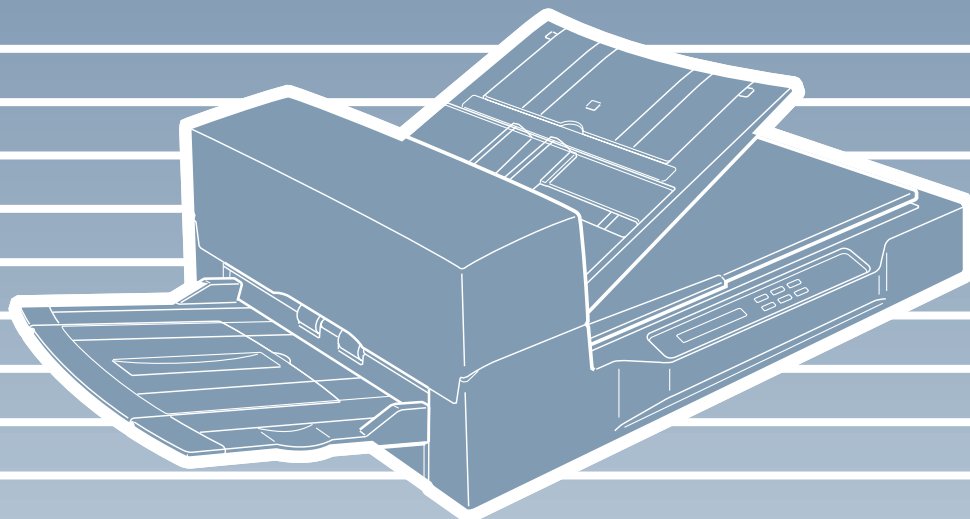

C150-E211-01EN

fi-4640S Image Scanner

Cleaning and Maintenance



FUJITSU

Revisions, Disclaimers

Revisions

Edition	Date published	Revised contents
01	July, 2001	First edition
Specification No. C150-E211-01EN		

FCC declaration: This equipment has been tested and found to comply with the limits for a Class B digital device, pursuant to Part 15 of the FCC Rules. These limits are designed to provide reasonable protection against harmful interference in a residential installation. This equipment generates, uses, and can radiate radio frequency energy and, if not installed and used in accordance with the instruction manual, may cause harmful interference to radio communications. However, there is no guarantee that interference will not occur in a particular installation. If this equipment does cause harmful interference to radio or television reception, which can be determined by turning the equipment off and on, the user is encouraged to try to correct the interference by one or more of the following measures:

- Reorient or relocate the receiving antenna.
- Increase the separation between the equipment and receiver.
- Connect the equipment into an outlet on a circuit different from that to which the receiver is connected.
- Consult the dealer or an experienced radio/TV technician for help.

FCC warning: Changes or modifications not expressly approved by the party responsible for compliance could void the user's authority to operate the equipment.

NOTE

- The use of a non-shielded interface cable with the referenced device is prohibited. The length of the parallel interface cable must be 3 meters (10 feet) or less. The length of the serial interface cable must be 15 meters (50 feet) or less.
- The length of the power cord must be 3 meters (10 feet) or less.

This Class B digital apparatus complies with Canadian ICES-003.

Cet appareil numérique de la classe B est conforme à la norme NMB-003 du Canada.

この装置は、情報処理装置等電波障害自主規制協議会（VCCI）基準に基づくクラスB情報技術装置です。この装置は、家庭環境で使用することを目的としておりますが、この装置がラジオやテレビジョン受信機に近接して使用されると、受信障害を引き起こすことがあります。取り扱い説明書に従って正しい取り扱いをして下さい。

High Safety Required Use: The Product is designed, developed and manufactured as contemplated for general use, including without limitation, general office use, personal use and household use, but is not designed, developed and manufactured as contemplated for use accompanying fatal risks or dangers that, unless extremely high safety is secured, could lead directly to death, personal injury, severe physical damage or other loss (hereinafter "High Safety Required Use"), including without limitation, nuclear power core control, airplane control, air traffic control, mass transport operation control, life support, weapon launching control. The Customer shall not use the Product without securing the sufficient safety required for the High Safety Required Use. In addition, Fujitsu (or other affiliate's name) shall not be liable against the Customer and/or any third party for any claims or damages arising in connection with the High Safety Required Use by the Customer of the Product.

As an ENERGYSTAR[®] Partner, Fujitsu Limited declares that this scanner meets the ENERGYSTAR[®] guidelines for energy efficiency. ENERGYSTAR[®] is a U. S. registered mark.

Changes

The contents of this manual may be revised without prior notice. FUJITSU reserves the right to make changes to any products herein, to improve reliability, function, or design, without further notice and without obligation.

Copyrights

All Rights Reserved, Copyright © 2001, FUJITSU LIMITED.

Printed in Japan.

No part of this manual may be reproduced in any form without permission.

Fujitsu Offices

Please send your comments on this manual or on Fujitsu products to the following addresses:

FUJITSU COMPUTER PRODUCTS OF AMERICA, INC.
2904 Orchard Parkway, San Jose.
California 95134-2022, U.S.A.
TEL: 1-408-432-6333
FAX: 1-408-432-3908
<http://www.fcpa.com/>

FUJITSU AUSTRALIA LIMITED
Fujitsu House 2 Julius Avenue North Ryde
N.S.W 2113 AUSTRALIA
TEL: 61-2-9776-4555
FAX: 61-2-9776-4019
<http://www.fujitsu.com.au/>

FUJITSU CANADA, INC.
2800 Matheson Blvd. East, Mississauga.
Ontario L4W 4X5, CANADA
TEL: 1-905-602-5454
FAX: 1-905-602-5457
<http://www.fujitsu.ca/>

FUJITSU DEUTSCHLAND GmbH.
Frankfurter Ring 211,
8000 München 40, F.R., GERMANY
TEL: 49-89-32378-0
FAX: 49-89-32378-100
<http://www.fujitsu.de/>

FUJITSU ESPAÑA, S.A.
Edificio torre Europa 5ª
Paseo de la Castellana 95
Madrid 28046, SPAIN
TEL: 34-1-581-8000
FAX: 34-1-581-8300
<http://www.fujitsu-europe.com/home/>

FUJITSU EUROPE LTD.
2, Longwalk Road, Stockey Park, Uxbridge
Middlesex, UB11 1AB, U.K.
TEL: 44-81-573-4444
FAX: 44-81-573-2643
<http://www.fujitsu-europe.com/home>

FUJITSU FRANCE S.A.
1, Place des Etats-Unis, SILIC 310,
94588 Rungis cedex, FRANCE
TEL: 33-1-4180-3880
FAX: 33-1-4180-3866
<http://www.fujitsu-europe.com/home/>

FUJITSU COMPUTERS (SINGAPORE) PTE, LTD.
20 Science Park Road #03-01, Tele Teck Park
Singapore Science Park II, Singapore 117674
Republic of Singapore
TEL: 65-777-6577
FAX: 65-771-5669
<http://www.fujitsu-computers.com.sg/>

FUJITSU HONG KONG Limited
10/F, Lincoln House, Taikoo Place,
979 King's Road, Island East, Hong Kong
TEL: 852-827-5780
FAX: 852-827-4724
TLX: 62667
<http://www.fujitsu.com.hk/>

FUJITSU ITALIA S.p.A.
Via Nazario Sauro, 38
20099 Sestos, Giovanni (MI), ITALY
TEL: 39-2-26294-1
FAX: 39-2-26294-201
<http://www.fujitsu-europe.com/home>

FUJITSU NORDIC AB
Kung Hans väg, S-192 68 Sollentuna, SWEDEN
TEL: 46-8-626-4500
FAX: 46-8-626-4588
<http://www.fujitsu-europe.com/home>

FUJITSU LIMITED
International Operations
Marunouchi 1-6-1, Chiyoda-ku,
Tokyo 100 JAPAN
TEL: (81-3)3216-3211
FAX: (81-3)3213-7174
TLX: J2283
Cable: "FUJITSU LIMITED TOKYO"
<http://www.fujitsu.co.jp/>

Note, Liability

READ ALL OF THIS MANUAL CAREFULLY BEFORE USING THIS PRODUCT. IF NOT USED CORRECTLY, UNEXPECTED INJURY MAY BE CAUSED TO USERS OR BYSTANDERS.

While all efforts have been made to ensure the accuracy of all information in this manual, FUJITSU assumes no liability to any party for any damage caused by errors or omissions or by statements of any kind in this manual, its updates or supplements, whether such errors are omissions or statements resulting from negligence, accidents, or any other cause. FUJITSU further assumes no liability arising from the application or use of any product or system described herein; nor any liability for incidental or consequential damages arising from the use of this manual. FUJITSU disclaims all warranties regarding the information contained herein, whether expressed, implied, or statutory.

Preface

This manual explains how to clean and maintain the fi-4640S image scanner.

The fi-4640S is a very fast and highly functional image scanner developed for high quality image processing, using charge-coupled device (CCD) image sensors. This scanner features high speed simplex scanning with an automatic document feeder (ADF).

Refer to the Operator's Guide for basic information about the fi-4640S.

Conventions

Important information that requires special attention is indicated as follows:



WARNING

WARNING indicates that serious personal injury may result if you do not follow a procedure correctly.



CAUTION

CAUTION indicates that minor personal injury, loss of data, or damage to the scanner may result if you do not follow a procedure correctly.





Official Fujitsu part names are indicated with an initial capital letter, as in the part name “Pick roller”.



NOTE

A NOTE provides “how-to” tips or suggestions to help you perform a procedure correctly.

CONTENTS

	CHAPTER 1 DESCRIPTION	1-1
	Units	1-2
	Assemblies	1-4
	Operator Panel	1-5
	Panel Display	1-6
<hr/>		
	CHAPTER 2 CLEANING	2-1
	Cleaning Supplies and Area Requiring Cleaning	2-2
	Supplies	2-2
	Areas Requiring Cleaning	2-3
	Cleaning the ADF	2-4
	Cleaning the Flatbed	2-10
<hr/>		
	CHAPTER 3 REPLACEMENT OF PARTS	3-1
	Pad Assembly	3-2
	Pick Roller	3-4
<hr/>		
	CHAPTER 4 TROUBLESHOOTING	4-1
	Clearing Paper Jams	4-2
	Initial Checks	4-3
	Problem Checklist	4-20

CHAPTER 1

DESCRIPTION

DESCRIPTION

CHAPTER 2

CLEANING

CLEANING

CHAPTER 3

REPLACEMENT OF PARTS

REPLACEMENT
OF PARTS

CHAPTER 4

TROUBLESHOOTING

TROUBLESHOOTING

DESCRIPTION

This chapter describes units, assemblies, indicators and LED functions.

Units

Assemblies

Operator Panel

Panel Display

Units

- ① ADF
- ② ADF lever
- ③ ADF paper chute

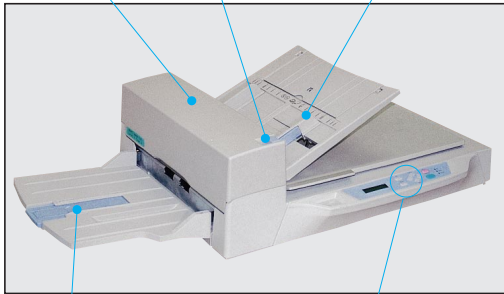

- ⑤ Stacker
- ④ Operator panel

- ⑥ Document cover
- ⑦ Document holding pad

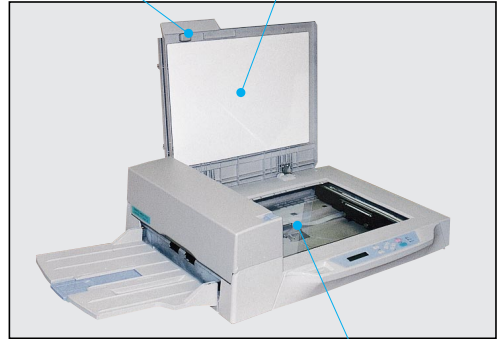

- ⑧ Document bed

- ⑨ Option board slot (Third party slot)

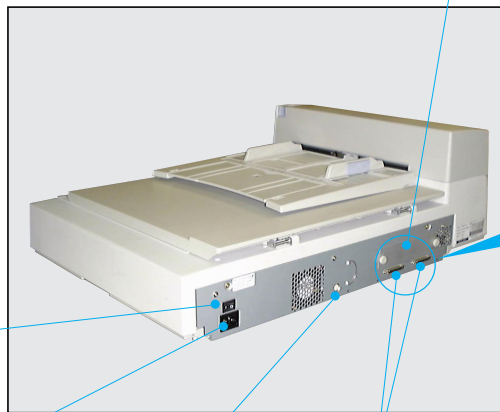

- ⑬ Power switch

- ⑫ Power inlet
- ⑪ EXT connector
- ⑩ Interface connector

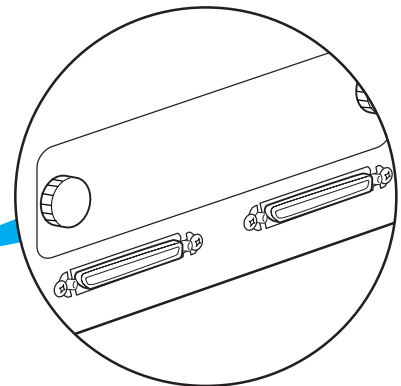

Nº	Function
①	Automatically feeds documents to the reading position.
②	Opens/closes ADF to enable the removal of jammed documents.
③	Holds the documents to be fed by ADF.
④	Displays the status of the scanner. Also displays buttons that enable the operator to change settings in Feed mode, Manual Feed mode, and Setup mode.
⑤	Stacks the read documents.
⑥	Covers the document to be read.
⑦	Presses the document to the Document bed.
⑧	Holds the document to be read. Also called Flatbed (FB).
⑨	An option board is installed.
⑩	Connects to the host system with interface cables.
⑪	Connects to an optional imprinter.
⑫	Connect the power cable from an AC power outlet here.
⑬	Power switch.

Assemblies

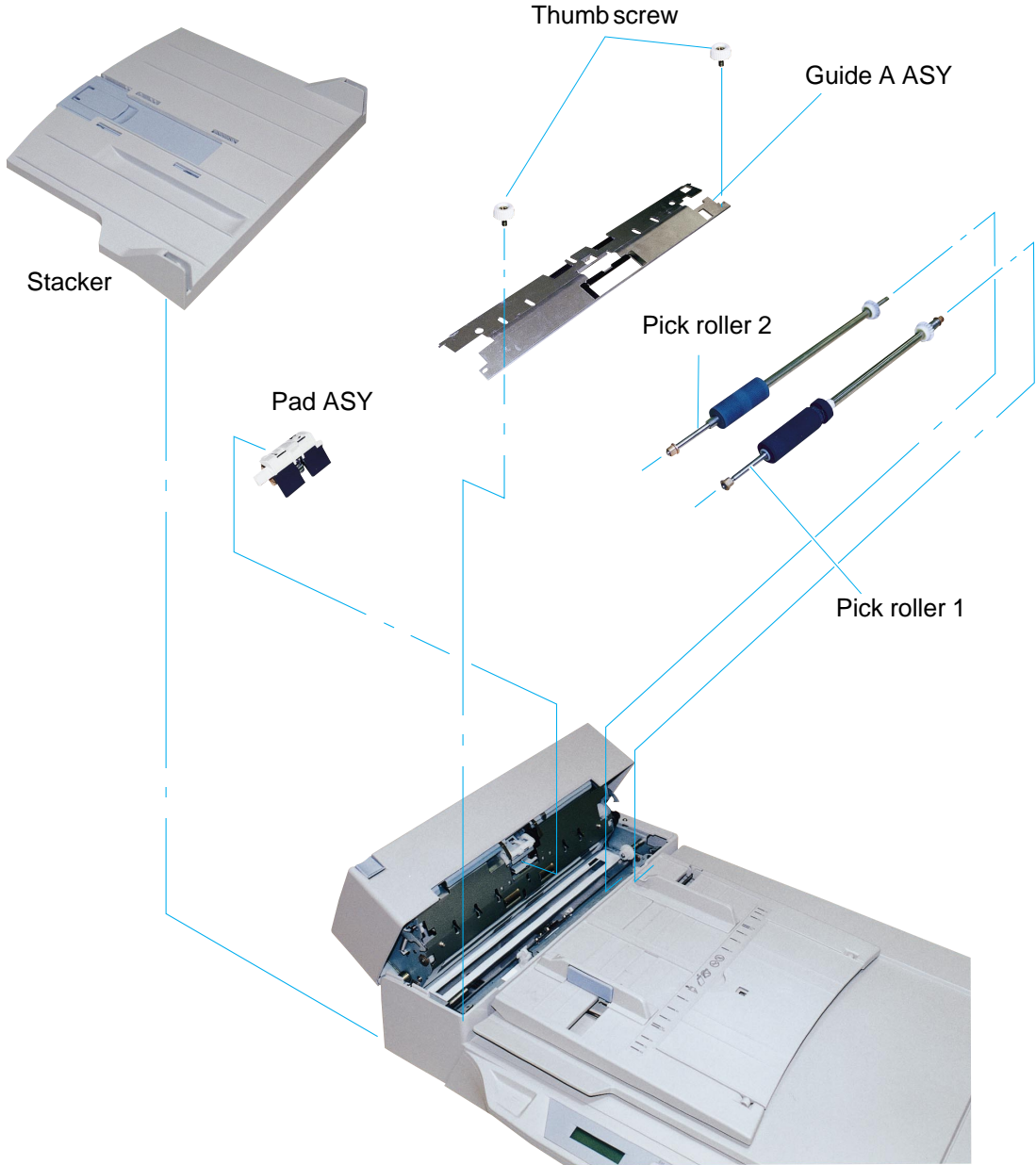

Operator panel

The Operator panel is located on the upper right hand side of the scanner. The panel consists of an LCD (16 characters x 2 lines), LEDs, and buttons.

Arrangement

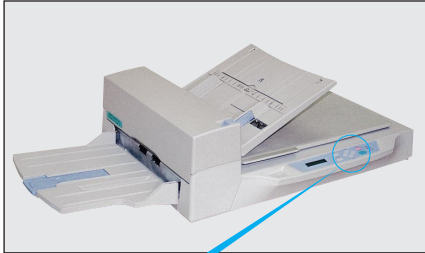

Operator panel

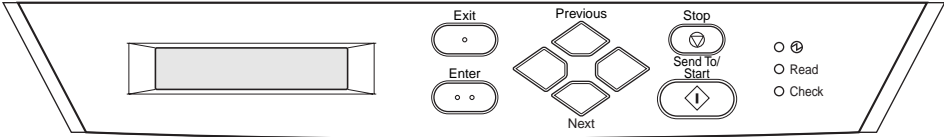

Panel Display



Button/LED Function

Name of the button and LED		Function
Button	Next ◊	Displays the next LCD screen.
	Previous ◊	Displays the previous LCD screen.
	◊	Moves the cursor to the left.
	◊	Moves the cursor to the right.
	Exit	When you are entering settings on the Operator panel, pressing this button returns you immediately to the Scanner Ready screen.
	Enter	Enters the parameter currently selected by the cursor.
	Send To/ Start	Operational only while the Read lamp lights when Manual start mode is set or the video interface option is used, and starts the reading. Some application software packages might use this button.
	Stop	Operational only during the read operation when the video interface option is used, and stops the reading. When the Check LED lights, pressing this button releases the error status (turns off Check and returns to the Scanner Ready screen). Also turns off the Check lamp.
LED	Ⓛ	Indicates that the scanner is On.
	Read	Indicates the scanner is reading or ready to read.
	Check	<ul style="list-style-type: none"> ● If lit, this indicates that an alarm occurred. Pressing the Stop button turns the Check lamp Off. ● If it blinks at one second intervals, this means that a jam or double feed has been detected. If the problem is jammed paper, removing the jammed paper turns off the Check lamp. If the problem is double feed, pressing the Stop button turns off the Check lamp. ● If it blinks at four seconds intervals, this means that cleaning the ADF is necessary.

Counter Display

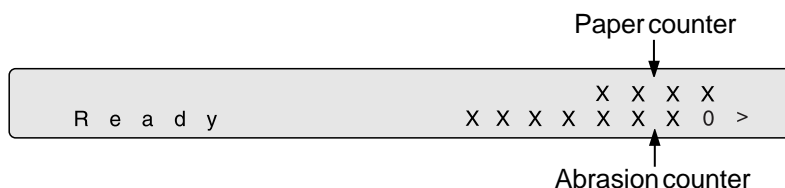
The scanner is provided with a counter display.



Counter	Function	
Paper counter	When the  button is pressed	The paper counter counts the number of scanned sheets from the start of reading until Paper Empty or until an error is detected. The counter is automatically reset at the start of reading. The counter is used for checking the number of sheets scanned at one time.
	When the  button is pressed	This counter increments each time a document is scanned. The counter is not initialized until the power is turned off. The counter can be used, for example, for checking the number of sheets that have been scanned in one day.
Abrasion counter	Abrasion counter counts the accumulated number of the scanned sheet. This counter increments at every 10 sheets. This counter is useful to check the cleaning cycle or parts replacement cycle. How to reset is described in Chapter 6 of the Operator's Guide.	

NOTE

When the counter value is 0, no number is displayed.

Panel Display

■ Operation status

The operation status is indicated by the following messages:

<Power-on>

W a r m i n g - u p N o w ! !

<Reading>

N o w R e a d i n g !

<Low Power Mode>

When the Scanner Display turns Off and the power  indicator remains “On”, the scanner is in the Low Power Mode.

NOTE

One of the following will wake up the scanner:

- Pressing any button.
- Setting the paper on the ADF.
- Sending a command from the host computer.

<Waiting for Start>

The scanner displays the following screen when waiting for the Start button to be pressed:

(Only When the Video Interface Option is installed.)

S t a r t S W O N !

<Cleaning request>

When the Pick roller cleaning is necessary, the scanner displays the following on the upper line:

C l e a n P i c k r o l l e r
N o w R e a d i n g !

When the ADF glass cleaning is necessary, the scanner displays the following on the LCD:

C l e a n A D F G l a s s
N o w R e a d i n g !

Clean the Pick roller or the ADF glass in accordance with the instructions given in chapter 2, Cleaning the ADF, and chapter 3, Pick Roller.

■ Temporary error

<Hopper empty>

P a p e r E m p t y

This message is displayed if there is no more paper on the ADF paper chute during a read operation in ADF mode. Fill the ADF paper chute with paper. To enable the read operation, press the stop button.

<Jam>

P a p e r J a m

This message is displayed if a document is jammed in the ADF. See Chapter 4 for removing jammed documents.

<ADF cover open>

A D F - C o v e r O p e n

This message is displayed if the ADF is not closed completely. Close the ADF completely, and enable the read operation.

<Double feed error>

D o u b l e F e e d

This message is displayed when the ADF detects a Double feed error. Check the document and re-scan it.

■ Alarm

One of the following messages is displayed if an error occurs in the scanner. If one of the following error messages is displayed, turn the power Off and then On again. If the same message is displayed, contact your service representative.

<Optical alarm>

O p t i c a l A l a r m

<FB mechanism alarm>

F l a t b e d
M e c h a n i c a l A l a r m

NOTE

When the total number of sheets scanned by the ADF is less than 100, the message above and the message below are displayed alternately. Remove the bracket (Shipping Lock) that holds the carrier in place.

C h e c k S h i p p i n g
L o c k

<Motor fuse alarm>

M o t o r f u s e A l a r m

<Lamp fuse alarm>

L a m p f u s e A l a r m

<Image transfer alarm>
(only when SCSI is used)

I m g T r a n s A l a r m

<Memory alarm>

M e m o r y A l a r m

<EEPROM alarm>

E E P R O M A l a r m

<FAN alarm>

F A N A l a r m

<IPC board alarm>

I P C B o a r d A l a r m

 **NOTE**

When this message is displayed, turn Off system power and then turn it On again. Alternatively, replace the current cable with one recommended by the manufacturer of the SCSI board. When the cause of the alarm has been corrected, the scanner automatically resumes operation once power is turned On again.

CLEANING

This chapter describes cleaning supplies, areas that require cleaning, and procedures for cleaning the ADF and the flatbed.

Cleaning Supplies and Areas Requiring Cleaning



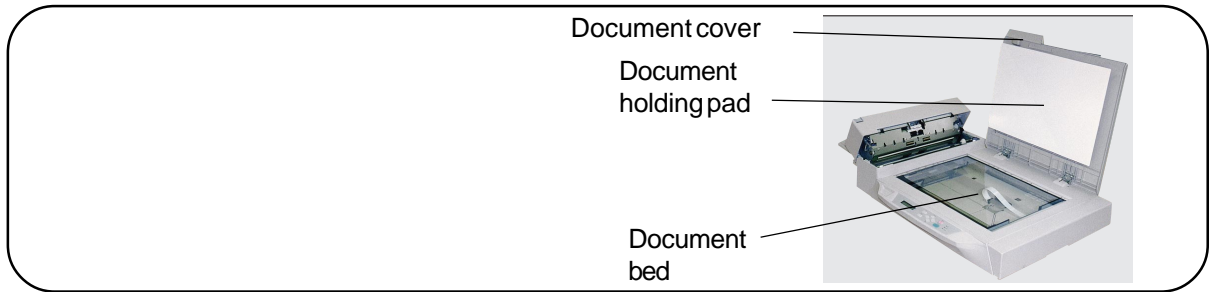

Cleaning the ADF

Cleaning the Flatbed

Cleaning Supplies and Areas Requiring Cleaning



Supplies

Supplies	Supply No.	Frequencies (*1)(*3)	Remarks
Cleaning paper 	0631180	Every 5,000 sheets	10 sheets
Cleaner F2 	0631160	• Plastic rollers (*2)	1 bottle Apply Cleaner F2 to cotton swab.
Cleaner F1 or Isopropyl alcohol 	0631150	• PAD assembly Every 5,000 sheets • Pick roller/Feed rollers/ Glass/Sheet guide Every 5,000 sheets	1 bottle. Apply Cleaner F1 to cloth.
Cotton swab 			
Dry cloth			

For more information on cleaning supplies, contact your dealer.

*1 If the display on the operator panel shows "Please clean Pick-roller", then clean it regardless of the frequencies recommended here.

*2  **CAUTION**

Do not clean the rubber rollers with cleaner F2.

*3 Refer to the Abrasion counter on the Operator panel to estimate when the next cleaning is necessary.

NOTE

When the following paper types are used, it may be necessary to clean more frequently:

- Paper with a smooth surface, such as coated paper.
- Paper almost entirely covered with printing.
- Paper with special chemical coatings, such as carbonless paper.
- Paper including a great quantity of calcium.
- When reading a great many documents written with a pencil.

Areas Requiring Cleaning

Area	Name	Cleaning paper with Cleaner F1	Dry cloth with Cleaner F1	Cotton swab with Cleaner F1 or F2
Flatbed	Document holding pad		○	
	Document bed		○	
ADF	Pad	○	○	
	Glass/Sheet guide	○	○	
	Pick roller	○	○	
	Plastic rollers	○	○	○
	Feed rollers	○	○	
	Pick arm rollers		○	○

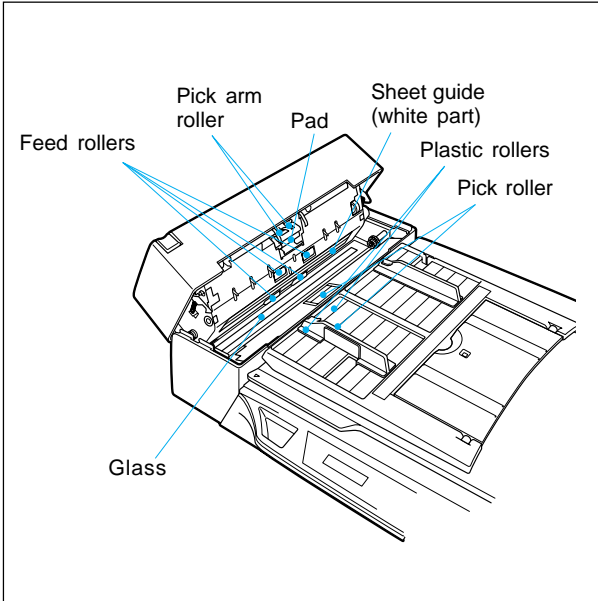
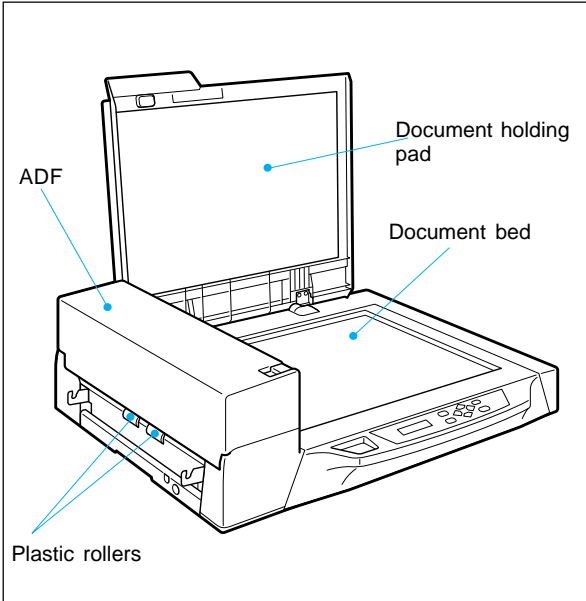

Cleaning the ADF

Cleaning the ADF with cleaning paper

- 1** Pull the ADF lever to open the ADF.
- 2** Lightly spray a new piece of cleaning paper with cleaner F1.
- 3** Place the cleaning paper on the ADF so that the edge of the short side touches the Plastic roller.
- 4** Close the ADF and turn the power on to start the cleaning.
- 5** After making sure the cleaning stops, turn the power off.
- 6** Turn the cleaning paper upside down, repeat steps 1 through 5.

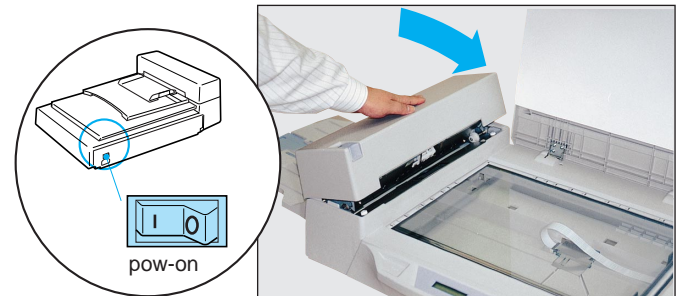
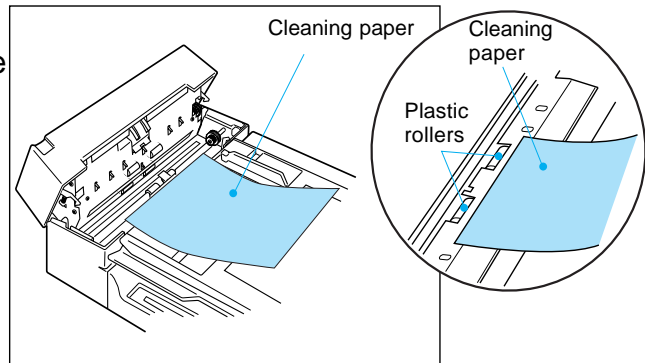
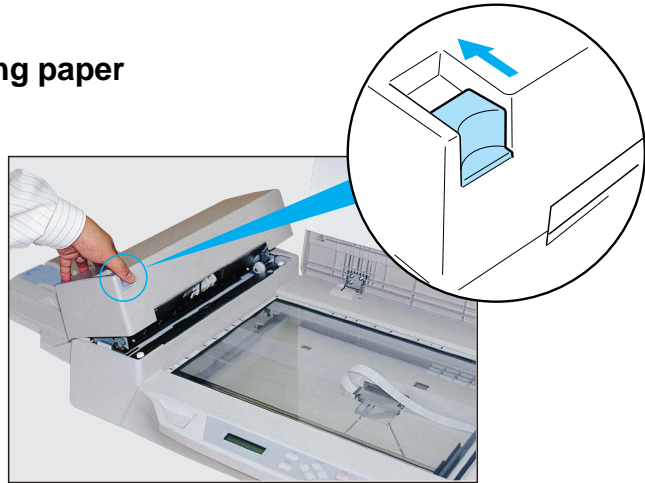

Cleaning the ADF with a Dry cloth or a Cloth with Cleaner F1

- 1** Pull the ADF lever to open the ADF.
- 2** Use a dry cloth or a cloth moistened with Cleaner F1 to softly remove dirt and dust as follows.

Pad assembly :

Wipe the pad in a downward direction (as indicated by the arrow). Be careful not to catch the spring for the Pick roller when wiping.



Glass:

Wipe the glass lightly.

NOTE

If the glass is dirty, the image may include black vertical stripes.

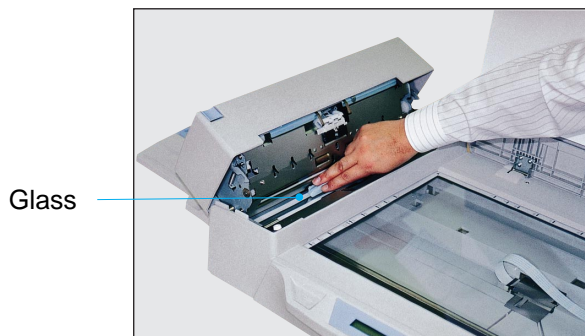

Pick roller:

Wipe the roller.

Be careful not to damage the surface of the roller and the mylar strip above the Pick roller.

Pick roller

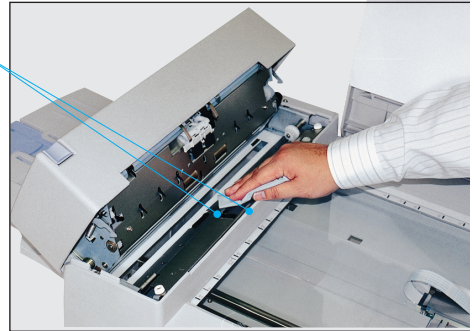

Feed rollers :
and Plastic rollers

Wipe the rollers.

Be careful not to damage the surface of the rollers.

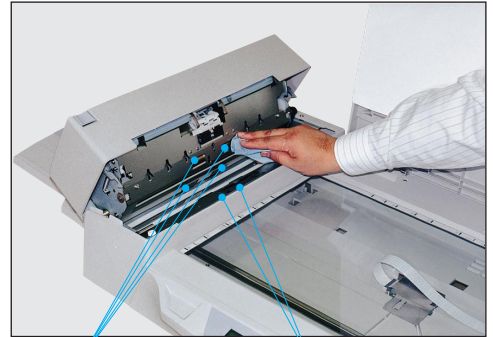

Feed rollers

Plastic rollers

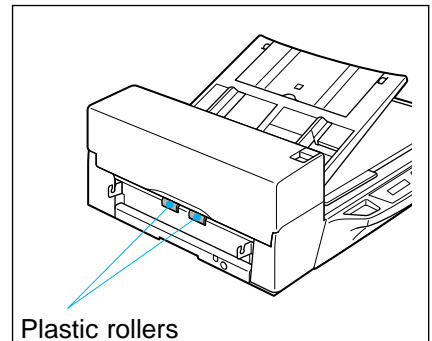

Plastic rollers

Sheet guide (white part):
Wipe the sheet guide.

 **NOTE**

If the Sheet guide is dirty, the front image may show vertical stripes.

Sheet guide (white part)

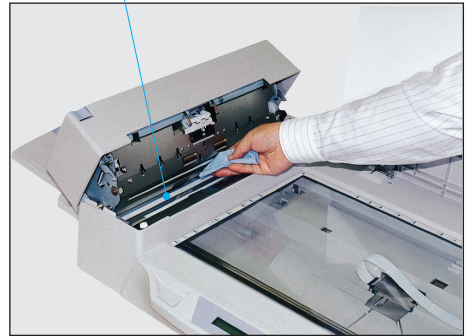

3 Close the ADF to lock the ADF lever.



CAUTION

Don't wipe the pad rubbers with the F2 cleaner.



Cleaning the Pick Arm Rollers

- 1** Pull the ADF lever to open the ADF.
- 2** Moisten a cotton swab or Dry cloth with F1 or F2 Cleaner.
- 3** Wipe the small Plastic rollers at the tip of the Pick Arm.
- 4** Wipe the small Plastic rollers and the Pick Arm with a clean, dry cloth to dry them.

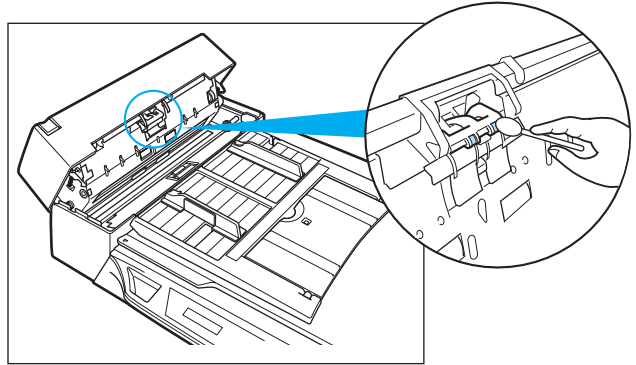

NOTE

When non-carbon paper is used, the Pick Arm rollers may become dirty with a black substance. Use Cleaner F2 to remove the contamination.



CAUTION

Don't wipe the pad rubbers with the F2 cleaner.

Cleaning the Plastic rollers with Cleaner F2

- 1 Pull the ADF lever to open the ADF.
- 2 Moisten a cotton swab with Cleaner F2.
- 3 Wipe the Plastic roller surfaces.

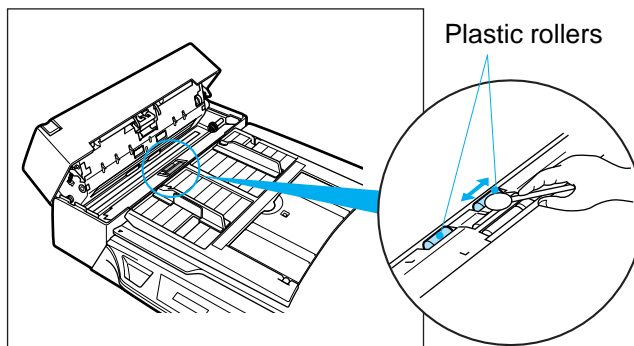

CAUTION

Don't wipe the Pick Rollers with a cotton swab using cleaner F2.

- 4 Wipe the Plastic roller surface with a clean, dry cloth. Allow it to dry.

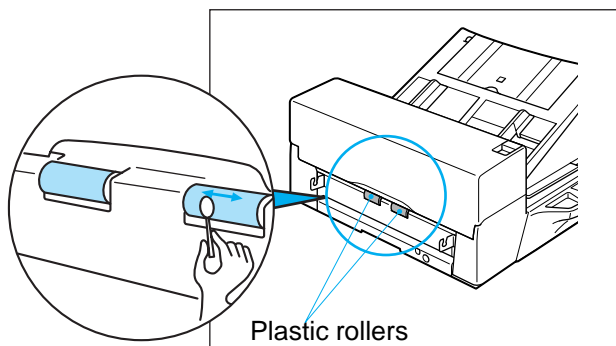

Cleaning the Flatbed

Cleaning the Flatbed with a Cloth and Cleaner F1

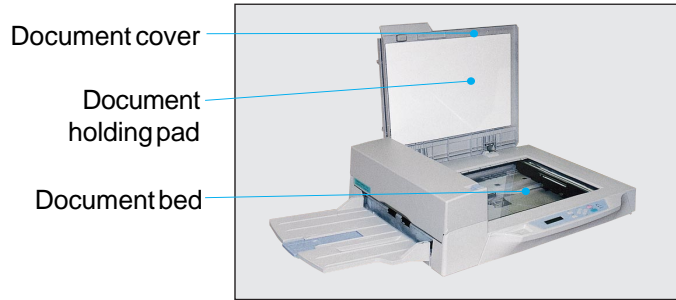

NOTE

Window or glass cleaner, excluding those not allowed for plastics, can be used instead of cleaner F1. However, do not use organic solvents like thinner.

.....

- 1** Open the Document cover.
- 2** Apply Cleaner F1 to a clean cloth.
- 3** Wipe the Document holding pad and the Document bed.
- 4** Allow them to dry.



NOTE

Be sure to prevent liquid from seeping through the opening between the Document bed and the plastic cover.

REPLACEMENT OF PARTS

This chapter describes how to replace the pad assembly and the pick roller.

Pad Assembly

Pick Roller

Pad Assembly

ADF lever

Pad ASY



NOTE

The life span of the pad assembly is about 100,000 sheets or one year. Use the Abrasion counter on the Operator panel to estimate when the Pad assembly needs replacement. The life span may be decreased by as much as half when carbonless paper is read frequently.



WARNING

Turn off the power before replacing the Pad Assembly.



Pick Arm

1

Pull the ADF lever to open the ADF.

2

Push the Pick Arm carefully.

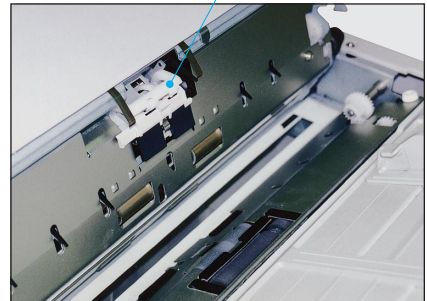

3 Slide the Pad Assembly to the left and pull it towards you. Then, being careful not to hook the spring for the Pad, remove the Pad Assembly.

 **NOTE**
Hold both ends of the Pad assembly as shown in the right photo.

 **CAUTION**
Don't hold the sensor arm with the Pad assembly.

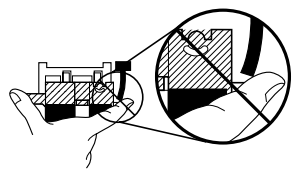
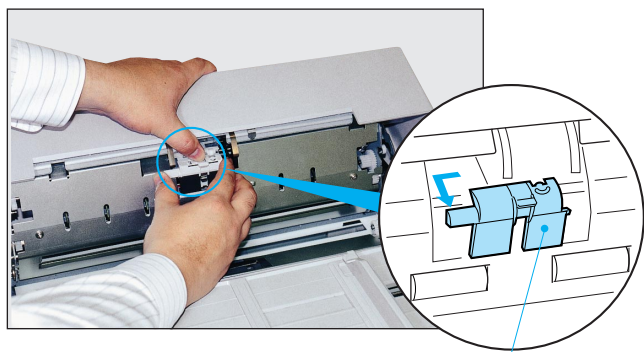

Pad assembly

4 Attach the Pad Assembly to the ADF in the reverse sequence of step 3.

 **NOTE**
Fit the Pad assembly pin into the larger hole, then slide it to the right until it stops.

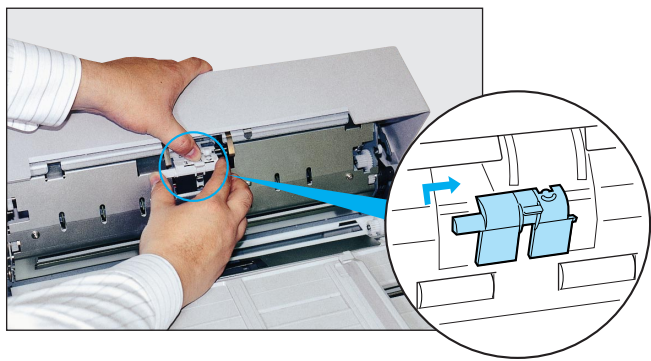

5 Close the ADF.



Pick Roller

Pick rollers
(Two rollers are included)



NOTE

The life span of the Pick roller is about 200, 000 sheets or one year. Use the Abrasion counter on the operator panel to estimate when the Pick roller needs replacement. The life span may be decreased by as much as half when carbonless sheets are frequently read.



WARNING

Turn off the power before replacing the Pick Rollers.

1

Pull the ADF lever to open the ADF.

2

Remove the two Thumb screws.



NOTE

Use a Phillips screwdriver if they are tight.



Thumb screws

- 3** With both hands, lift up Guide A and disengage its tip from the right hole. Then lift the right side of the cover and remove it.

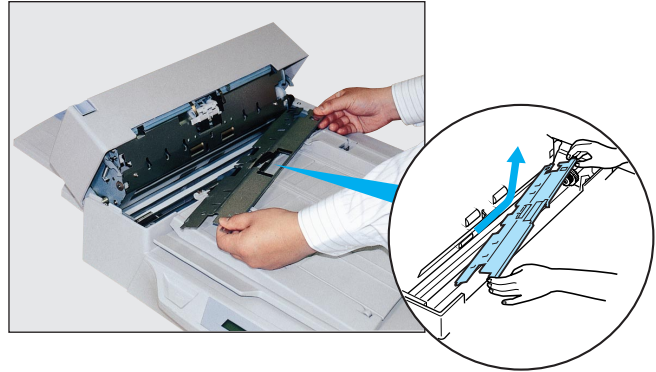

- 4** To remove the Pick rollers, turn the stopper counter-clockwise.

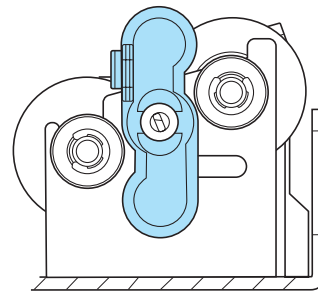
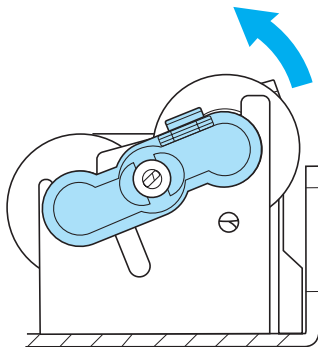
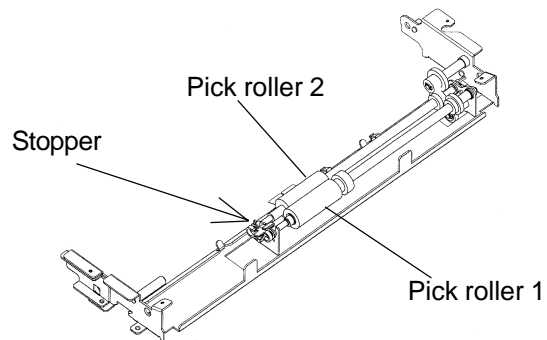

Position for Replacement

- 5** To remove the Pick roller 1, move it to the left and then lift it.

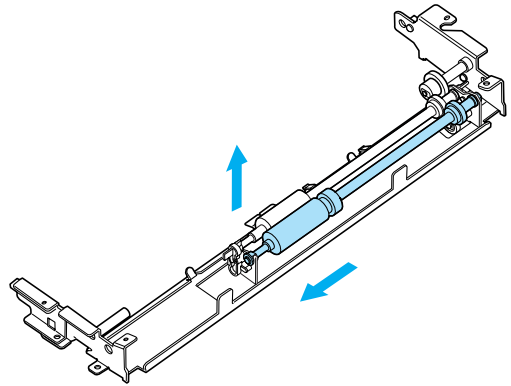

-
- 6** Immediately after removing the Pick roller 1, remove the Pick roller 2 in the same way.

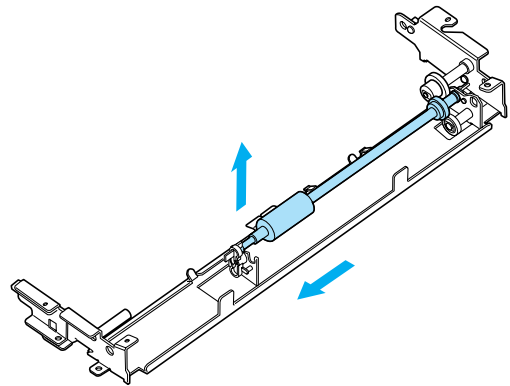

- 7** To attach the new Pick rollers, place Pick roller 1 from the right side above the bearing for Pick roller 1.

 **NOTE**

Pick roller 1 has a groove in its rubber.

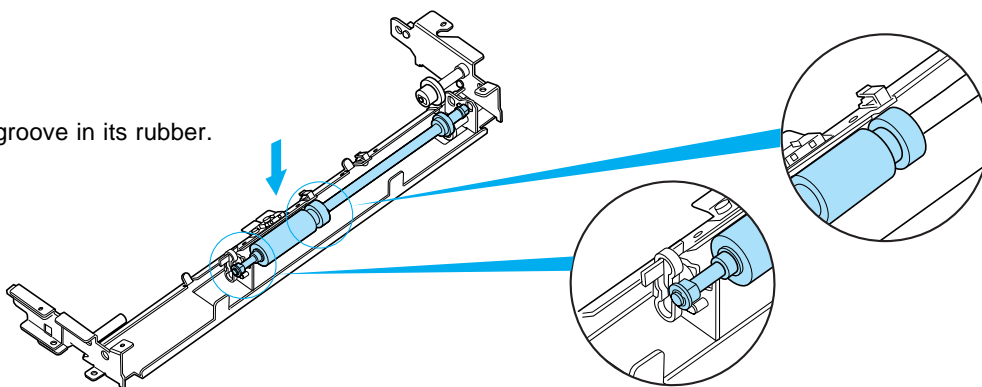

Put the shaft of Pick roller 1 into the bearing. Then, slide Pick roller 1 toward the right side.

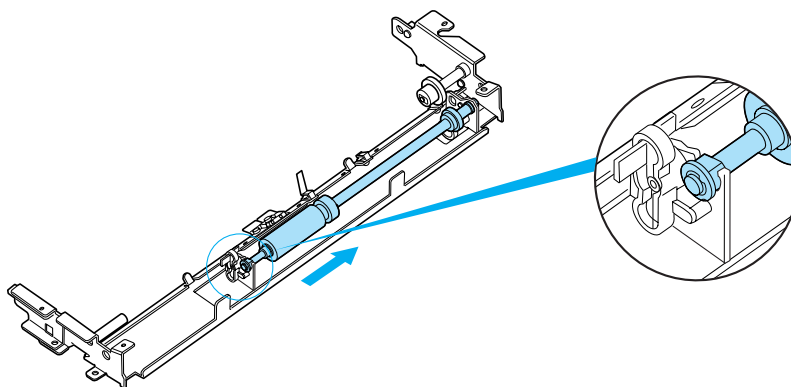

 **NOTE**

Make sure that the shaft is securely fixed to the bearings.

- 8** Attach Pick roller 2, in the same way as Pick roller 1 as shown in step **7**.

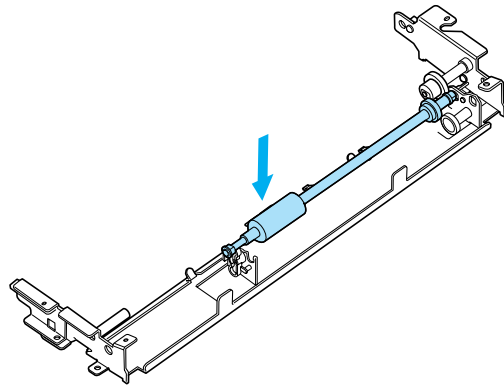

Then slide the Pick roller 2 toward right side.

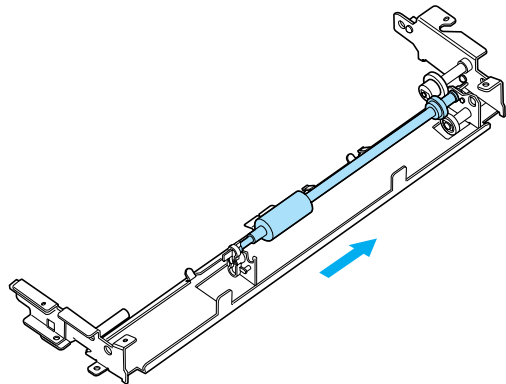

 **NOTE**

Make sure that the shaft is securely fixed to the bearings.

- 9** Turn the stopper clockwise to secure the Pick rollers.

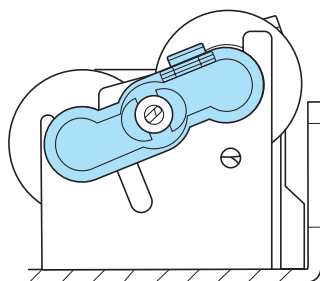
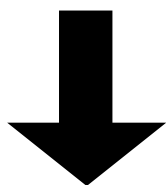
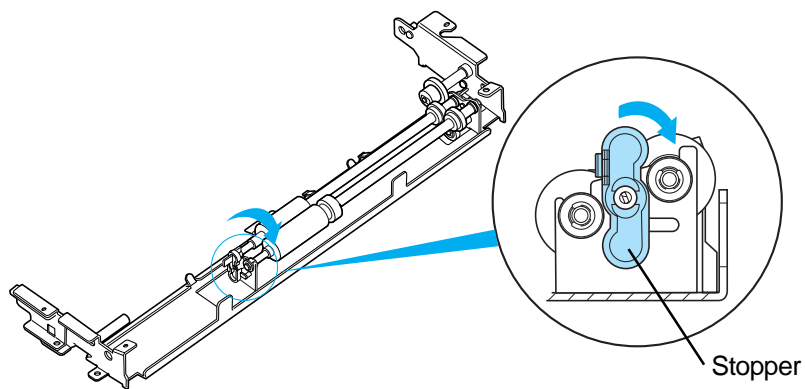

Operating Position

- 10** Attach Guide A in the reverse sequence of step 3 and align the screw hole. See the graphic on page 1-4.

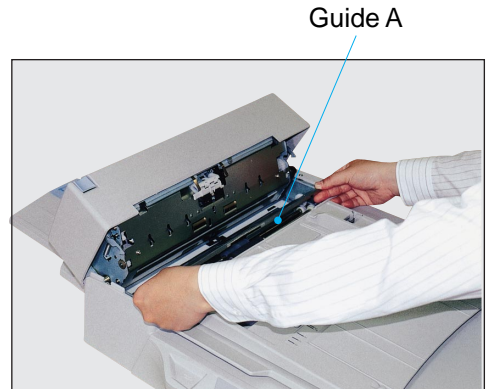

- 11** Tighten the thumb screws.

- 12** Close the ADF unit.

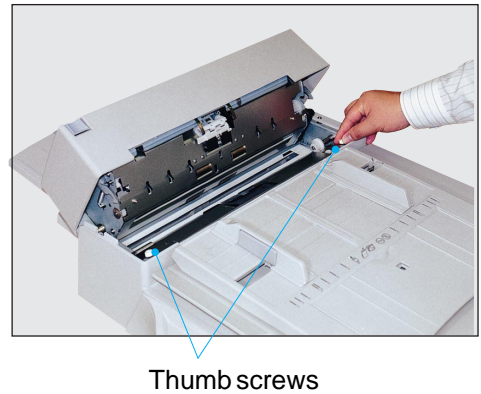

TROUBLESHOOTING

This chapter describes how to clear paper jams and run initial checks. It also contains a Problem Checklist that should be completed before you call a service representative.

Clearing Paper Jams

Initial Checks

Problem Checklist

Clearing Paper Jams

Document

ADF

ADF lever

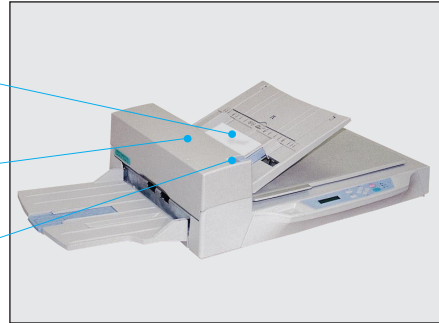

1

Remove all the documents from the ADF paper chute.

2

Pull the ADF lever to open the ADF.

3

Remove the jammed document(s).



NOTES

- Inspect the paper and the paper path. Make sure no staples, paper clips or other materials caused the jam. All staples and paper clips should be removed from all documents before scanning.
- Be careful not to pull the spring for the Pad while removing a jammed document.

4

Close the ADF so that the ADF lever locks.



Initial Checks

If a problem occurs, check the following items before contacting the manufacturer's authorized service center.

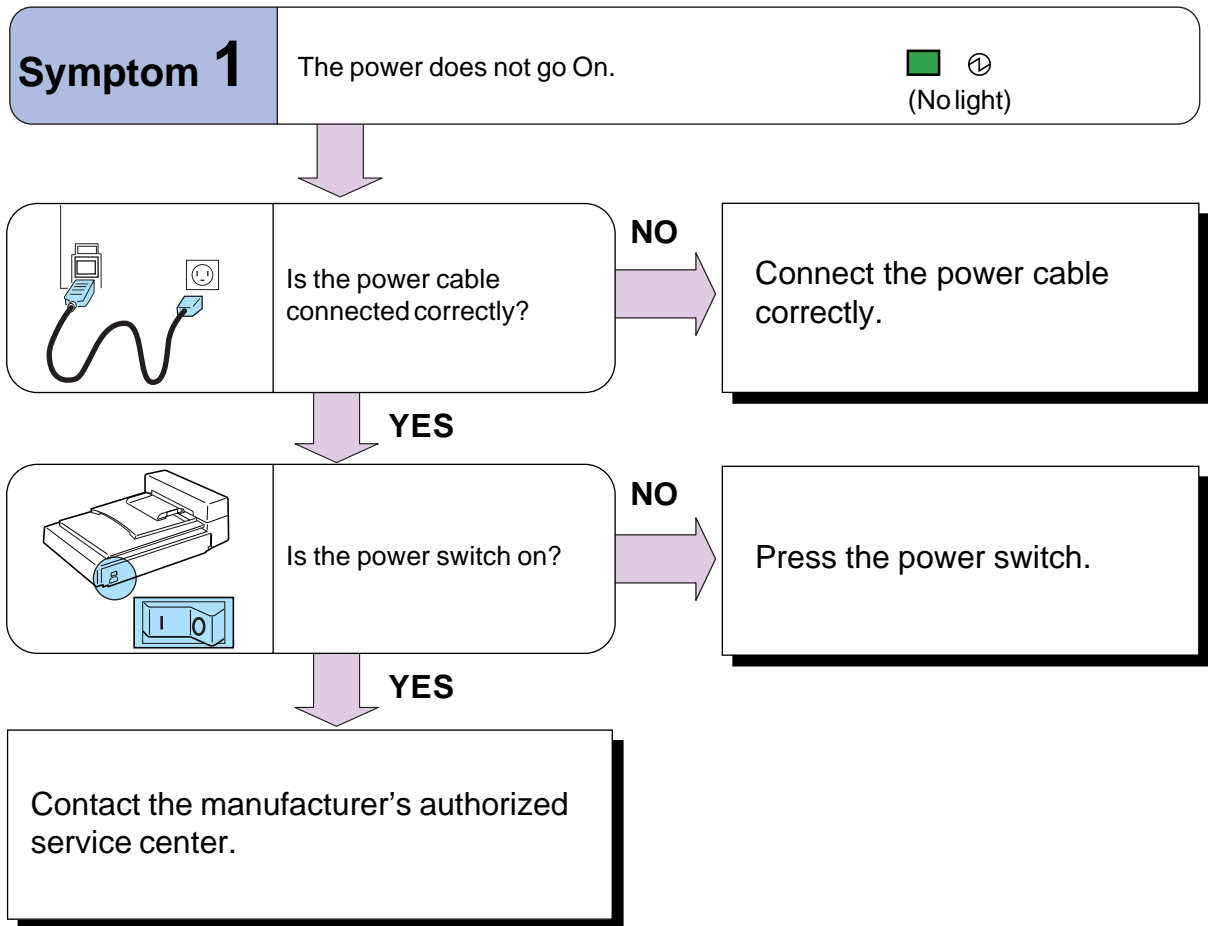

Symptom 2

The operator panel turns "Off".

 Power "On"

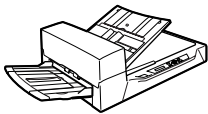

Has it been a long time since the scanner was last used?

YES

Press any button on the operator panel to wake up the system.

NO

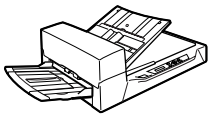

Did the scanner enter this state quickly?

YES

Extend the time for entering "Low Power Mode" in Set Up Mode.

NO

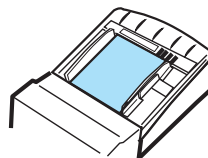

Did you load the paper on the ADF?

YES

Load the paper again, or press any button on the operator panel.

NO

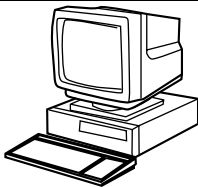

Have 10 seconds passed since the PC instructed a scan?

YES

Wait for at least 10 seconds.

YES

Contact the manufacturer's authorized service center.

Symptom 3

Read operation does not start.

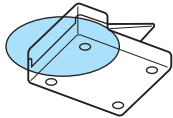

Is the Shipping Lock placed in an operating position?

NO

Place the Shipping Lock correctly.
(See the Operator's Guide, p. 2-4)

YES

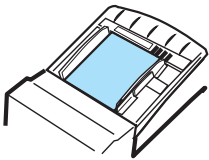

Are the documents loaded correctly on the ADF paper chute?

NO

Insert the documents into the slot.

YES

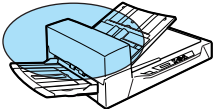

Is the ADF completely closed?

NO

Completely close the ADF.

YES

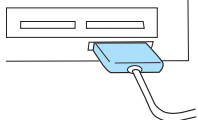

Is the interface cable connected correctly?

NO

Connect the interface cable correctly.

YES

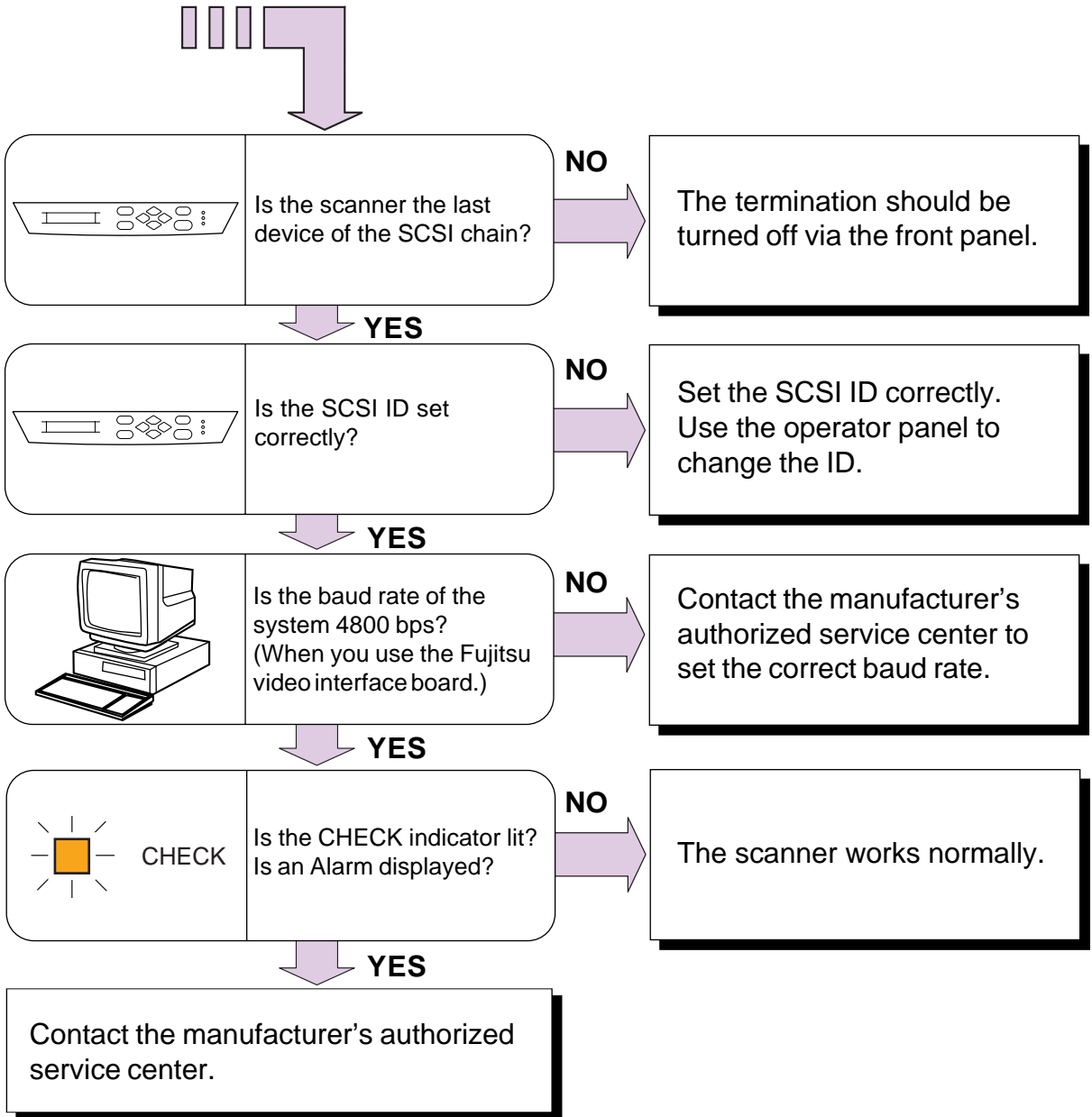

Symptom 4

Pictures and photographs are not read correctly.

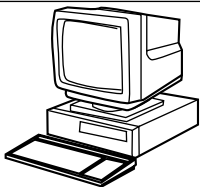

Is the "Photo" mode selected?

NO

Select the "Photo" mode (White level following "Off") through the scanner setting menu in the software.

YES

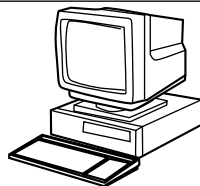

Is halftone or dither processing selected?

NO

Select the halftone or dithering mode from the host computer.

YES

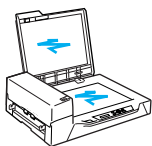

Are the Document bed, Document holding pad, glass, and sheet guides clean?

NO

Clean the dirty parts. (See p. 2-5, p. 2-7, p. 2-10)

YES

Contact the manufacturer's authorized service center.

Symptom 5

Characters and lines are not read correctly.

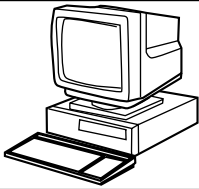

Is the "Line Art" mode selected?

NO

Select the "Line Art" mode from the host computer.

YES

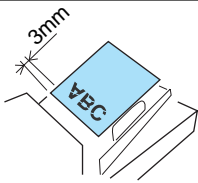

Is there any printed text on the first 3mm of the document?

YES

Select the "Photo" mode (White level following "Off") via software.

NO

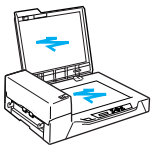

Are the Document bed, Document holding pad, glass, and sheet guides clean?

NO

Clean the dirty parts. (See p. 2-5, p. 2-7, p. 2-10)

YES

Contact the manufacturer's authorized service center.

Symptom 6

Images are distorted or unclear.

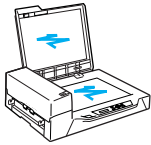

Are the Document bed, Document holding pad, glass and sheet guides clean?

NO

Clean the dirty parts.
(See p. 2-5, p. 2-7, p. 2-10)

YES

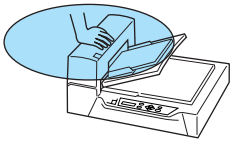

During rear read operation with the ADF, is the top of the ADF being pressed or is there anything heavy on it?

YES

Do not press the top of the ADF or put anything heavy on it.

NO

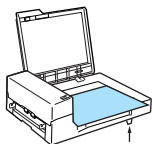

missing

Is the scanner on an even and flat surface or are any rubber feet of the scanner missing?

NO

Place the scanner on a flat, even surface or attach the rubber feet.

YES

Contact the manufacturer's authorized service center.

Symptom 7

Images have vertical lines.

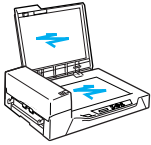

Did you scan the document using the Flatbed?
Are the lines white?

YES

Contact the manufacturer's authorized service center.

NO

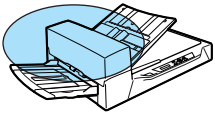

Are the lines black?

YES

Clean the ADF Glass.

NO

Contact the manufacturer's authorized service center.

Symptom 8

Immediately after power is turned on, the Check indicator is on.

 CHECK

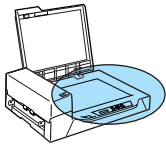

Is the Shipping Lock placed in operating position?

NO

Place the Shipping Lock correctly.
(See Operator's Guide.)

YES



CHECK

Turn off the power once and then try to turn on the power again. Is the CHECK lamp still on? Or is an Alarm displayed?

NO

The scanner works normally.

YES

Contact the manufacturer's authorized service center.

Symptom 9

“Please clean Pick-roller” is displayed.

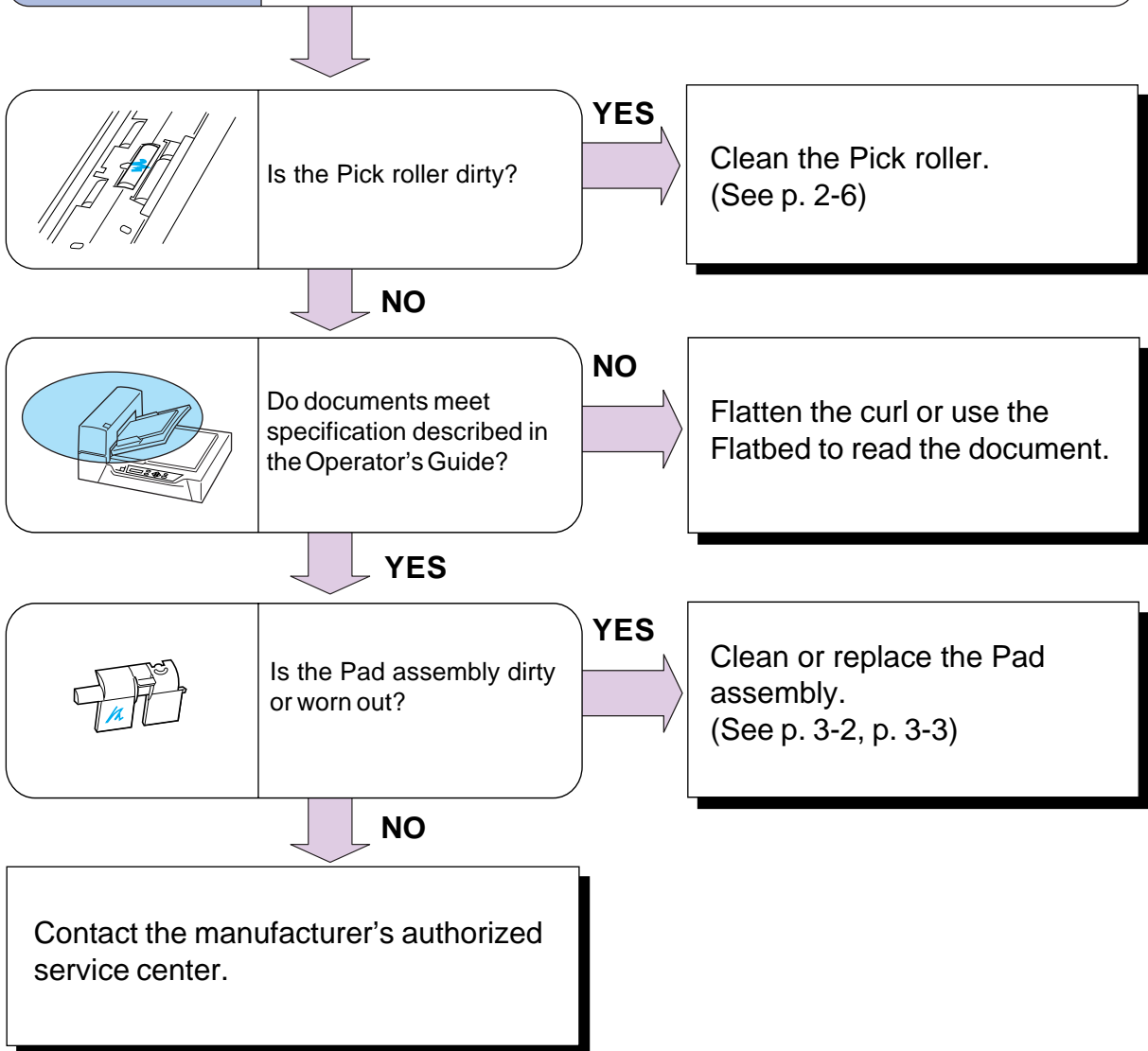

NOTES

NOTES

- Remove paper clips and staples. Flatten the staple holes.

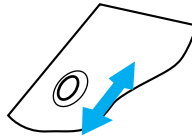

- Read the following types of documents using the Flatbed:
 - Paper with clips or staples.
 - Paper with wet ink.
 - Paper of uneven thickness (for example, envelopes).
 - Paper with large rumples or curls.
 - Paper with folds or tears.
 - Tracing paper.
 - Coated paper.
 - Carbon paper.
 - Paper shorter than A8 size (portrait) or larger than A3 or 11 x 17 inches.
 - Materials other than paper (for example, cloth, sheet metal, or OHP film).
 - Photographic paper.
 - Paper with perforations on its sides.
 - Non-rectangular paper.
 - Very thin paper.

- The leading edge of all documents fed by the ADF should be straightened so the curl of the paper meets the specifications below:

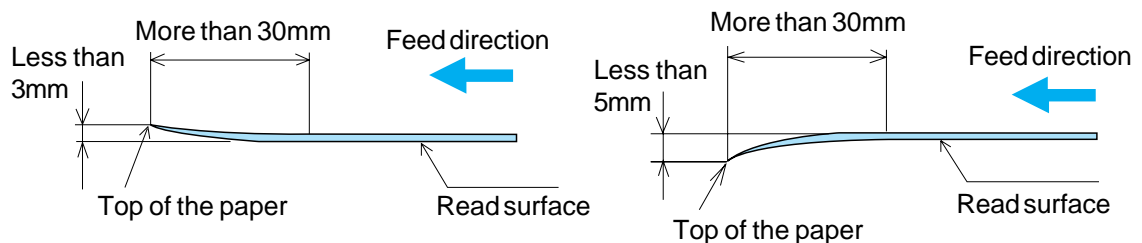

- Do not mix documents of different widths.

Symptom 10

Paper double feed occurs frequently.

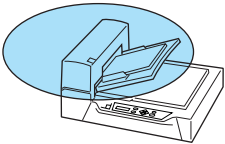

Does the condition of the documents meet the requirements described in the Operator's Guide?

NO

Flatten the curl or use the Flatbed to read the documents.

YES

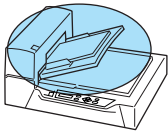

When double feed detection is ON, are all the documents of the same length?

NO

Set double feed detection to "Off". (See the Operator's Guide)

YES

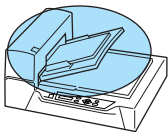

Are the documents fanned before being loaded on the ADF paper chute?

NO

Fan the documents before loading, or reduce the batch size.

YES

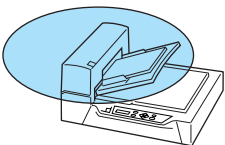

Have the documents recently been printed by copier or laser printer?

YES

Fan the stack 3 or 4 times to remove the static charge applied to the paper.

NO

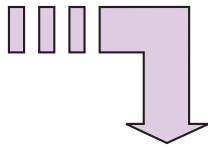

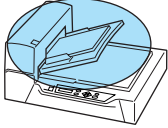
	Is the document stack less than 0.32" (8mm) in height?	NO	Reduce the batch size of the documents.
---	--	-----------	---

YES

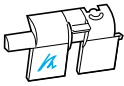
	Is the Pad dirty?	YES	Clean the Pad assembly. (See p. 2-4)
---	-------------------	------------	--------------------------------------

NO

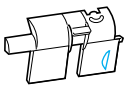
	Is the Pad worn out?	YES	Replace the Pad assembly. (See p. 3-2)
---	----------------------	------------	--

NO

Contact the manufacturer's authorized service center.

Symptom 11

Mispick occurs frequently.

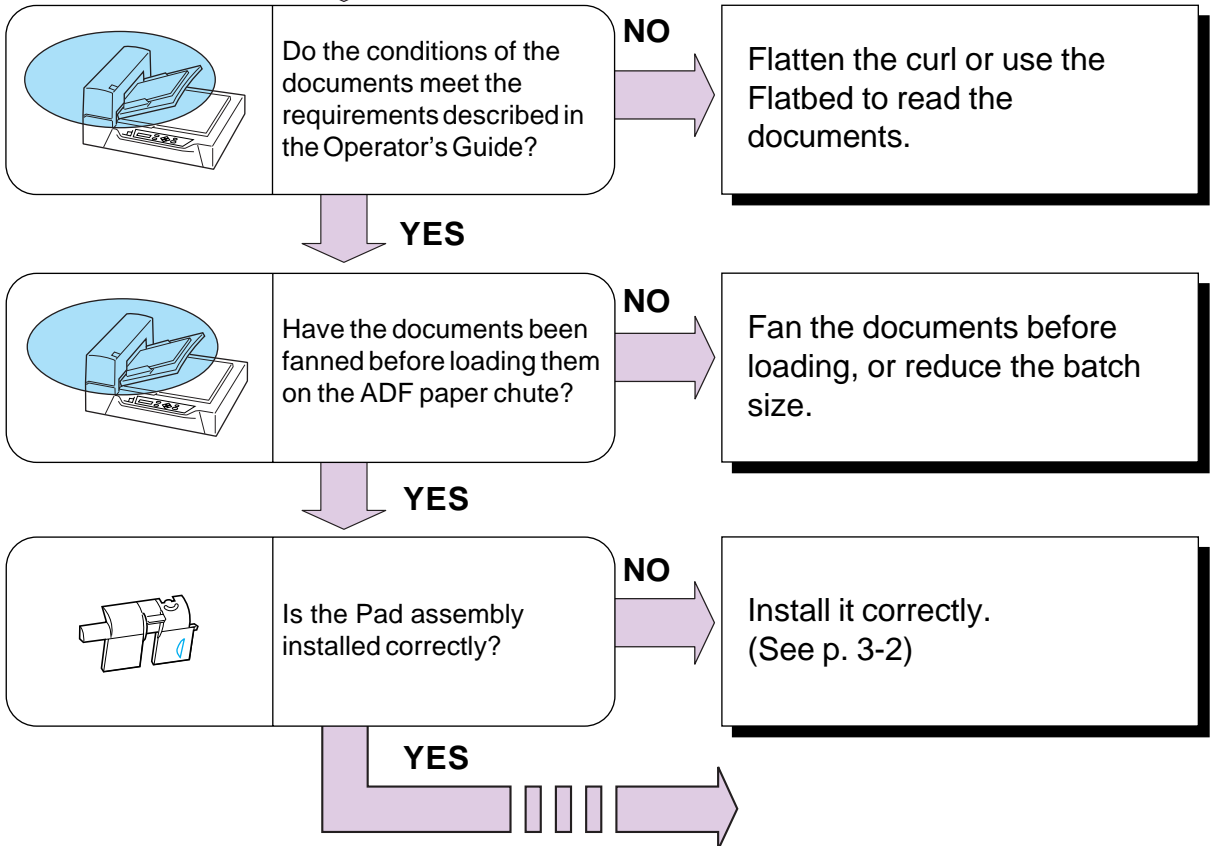

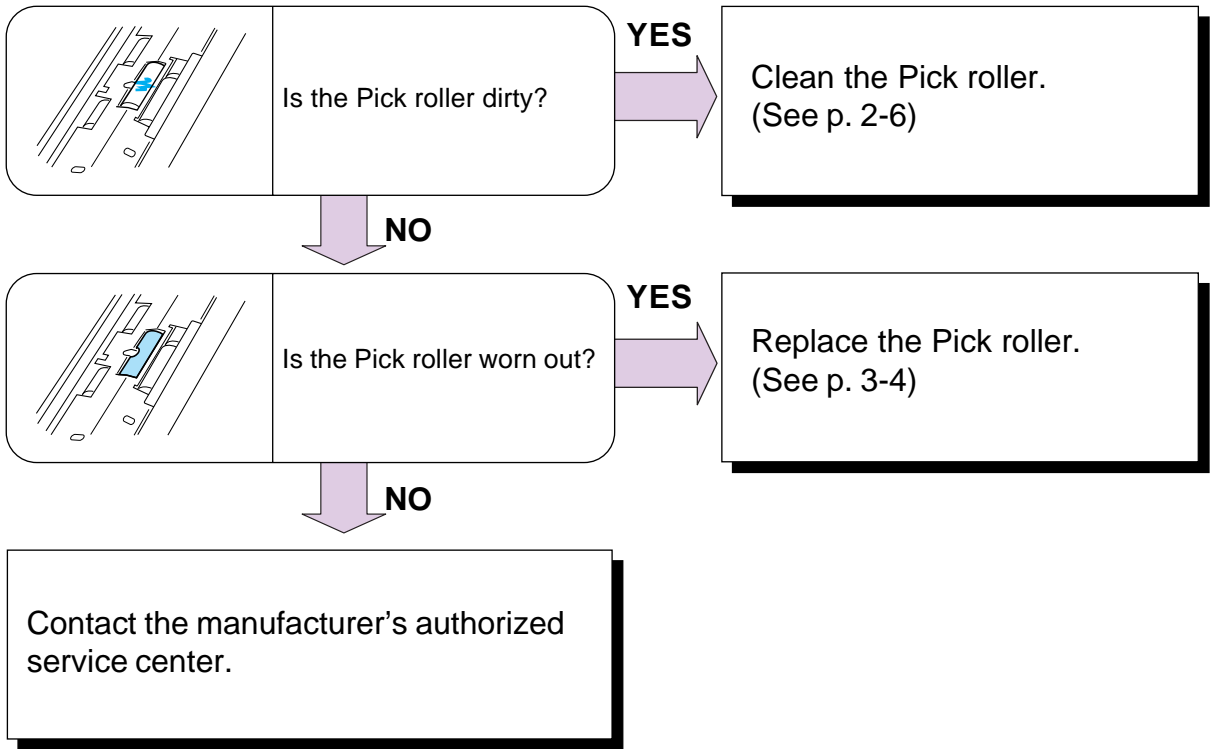
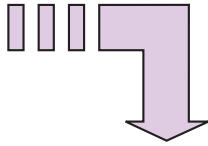

Symptom 12

Paper jams occur frequently.

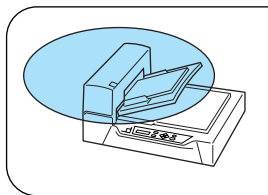

Does the condition of the document meet the requirements on page 4-13?

NO

Flatten the curl or use the Flatbed to read the document.

YES

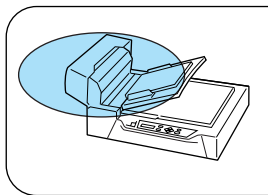

Are there any foreign particles in the ADF?

YES

Clean the ADF (see p. 2-4) or remove the foreign particles.

NO

Contact the manufacturer's authorized service center.

Symptom 13

"Please clean ADF glass" is displayed.

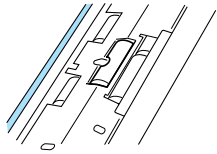

Is the ADF glass dirty?

YES

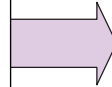

Clean the ADF glass.
(See p. 2-5)

NO



Contact the manufacturer's authorized
service center.

Problem Checklist

Before contacting the manufacturer's authorized service center, please fill in the following items.

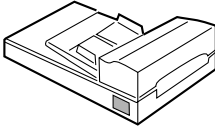
■ General																																												
Model																																												
Part number																																												
Serial number																																												
Manufactured date																																												
Revision	<table border="1"> <tr> <td></td> <td></td> <td></td> <td></td> <td></td> <td></td> <td></td> <td></td> <td></td> <td></td> </tr> <tr> <td>A</td> <td>0</td> <td>1</td> <td>2</td> <td>3</td> <td>4</td> <td>5</td> <td>6</td> <td>7</td> <td>8</td> <td>9</td> </tr> <tr> <td>B</td> <td>0</td> <td>1</td> <td>2</td> <td>3</td> <td>4</td> <td>5</td> <td>6</td> <td>7</td> <td>8</td> <td>9</td> </tr> <tr> <td>C</td> <td>0</td> <td>1</td> <td>2</td> <td>3</td> <td>4</td> <td>5</td> <td>6</td> <td>7</td> <td>8</td> <td>9</td> </tr> </table>											A	0	1	2	3	4	5	6	7	8	9	B	0	1	2	3	4	5	6	7	8	9	C	0	1	2	3	4	5	6	7	8	9
A	0	1	2	3	4	5	6	7	8	9																																		
B	0	1	2	3	4	5	6	7	8	9																																		
C	0	1	2	3	4	5	6	7	8	9																																		
<p>The revision is printed on the label located at the left corner of the back. The revision is indicated by the double line. This example shows the revision A2.</p>																																												
Date of purchase																																												
Symptoms																																												
Persistent problem?																																												
Serviced before (when and how)?																																												
Error status																																												
■ Transport error																																												
Type of document.																																												
What is your daily usage?																																												
Date of last cleaning.																																												
Date of the consumable replacement.																																												
■ Image error																																												
Interface controller model																																												
Software/application name																																												
Can you send the original and output of sheet by facsimile or by mail?																																												

The image features a background of horizontal stripes in various shades of blue and grey. At the top, there is a solid dark blue horizontal bar. Below it, the stripes alternate between medium blue, light blue, and grey. The Fujitsu logo is centered in the middle of the page. It consists of a stylized infinity symbol above the word "FUJITSU" in a bold, sans-serif font.

FUJITSU